

# STANDARDS AND GUIDELINES FOR SAFETY IN FENCING

## 23RD EDITION

Last Updated: May 2026

Approved by Board: 25<sup>th</sup> June 2026

**This document is issued by British Fencing to ensure that fencing remains one of the safest sports.**

All involved in fencing, standing or seated, should follow the guidelines.

In particular: -

**Coaches/instructors** have a special responsibility for safety during training and should especially study section 3 + appendix 1. They should also give careful consideration to the circumstances in which they are prepared to instruct pupils who are not wearing full protective clothing.

**Referees** have an important safety role in competitions. They have the authority to prevent the use of unsafe equipment and to penalise dangerous play. It is in the best interests of the fencers and the sport that they should always do so. Additional guidance is included as footnotes at the bottom of some pages.

British Fencing (BF) specifies certain minimum safety standards for fencing clothing in line with European CEN standards for Personal Protective Equipment (PPE) – see Appendix 1 (Chart of BF Clothing and Weapon Rules).

Accidents and injuries are rare in fencing. In the case of any accident, injury, serious medical incident or near miss please ensure a BF [Accident and Injury Report](https://app.smartsheet.com/b/form/58ff7faa98ed427fa6f9049f8ea99762) (<https://app.smartsheet.com/b/form/58ff7faa98ed427fa6f9049f8ea99762>) is submitted.

Reviewing accident and injury reports is one of the most useful ways to monitor and improve safety standards.

Reports of incidents causing withdrawal from a fencing-related activity for both fencers or non-fencers are especially important but all reports are helpful.

Appendix 1 is the Chart of BF Clothing and Weapon Rules

Appendix 2 deals with legal responsibility and liability.

Appendix 3 provides advice on the running of classes

Appendix 4 describes the role of CE marks on equipment – CE certification is legally required for all safety equipment sold in the UK or mainland Europe

### CONTENTS

1.	Protection, personal and of opponents.....	4
1.1	General .....	4
1.2	Masks .....	4
1.3	Jackets & Breeches .....	5
1.4	Plastrons .....	6
1.5	Chest protectors.....	6
1.6	Gloves .....	6
1.7	Socks and shoes.....	6
1.8	Fencing with foam or plastic weapons, and the SabreLite programme. ..	6
2.	Weapons.....	6
2.1	Weapons - General .....	6
2.2	Weapons - Blades.....	7
2.3	Weapons - Blades for children.....	7
2.4	Weapons - Tips & Guards.....	7
3.	Special Guidelines for Children .....	8
3.1	Child protection/welfare:.....	8
3.2	Blade sizes.....	8
3.3	Clothing.....	8
3.4	Lessons/classes .....	8
4.	Fencing Activities.....	8
4.1	Venues .....	9
4.2	Clubs, lessons, classes .....	10
4.3	Lessons/classes - protective clothing .....	10
4.4	Sparring in beginner/taster classes - protective clothing .....	11
4.5	Competitions.....	11
4.6	Accident and Injury Reporting.....	12
5.	First aid .....	12
5.1	Facilities/personnel.....	12
5.2	Intervention .....	13
6.	APPENDIX 1: Mandatory Minimum Standards - Chart of BF Clothing & Weapon Rules in Clubs and at Competitions .....	14

## BF SAFETY GUIDELINES

6.1	All Plastic/Foam Fencing.....	14
6.2	Steel blades - Club Beginner Course (inc Supervised sparring)/Public Come and Try .....	14
6.3	Steel blades - Fencer taking lesson.....	15
6.4	Traditional non-electric foil blade Activities.....	15
6.5	SabreLite .....	16
6.6	Under 10/size 0 blades (both fencers) .....	16
6.7	Under 14 fencing with size 2/3 blades .....	17
6.8	British Youth Championships.....	17
6.9	Other sparring in clubs .....	17
6.10	British National Championships (Cadet, Junior, U23 & Senior).....	18
6.11	Other UK competitions .....	18
6.12	ALL FIE & U17/U23 EFC competitions .....	18
7.	APPENDIX 2: Legal Responsibility.....	20
8.	APPENDIX 3: Advice on Running Classes .....	21
9.	APPENDIX 4 - CE, CEN and FIE Markings .....	22

# 1. PROTECTION, PERSONAL AND OF OPPONENTS

## 1.1 GENERAL

BF has laid down standards for personal protective clothing to be worn.

These standards are set out in a chart at the end of these Safety Guidelines, in Appendix 1 (chart of BF clothing rules).

These standards apply to fencing at competitions and everywhere else that fencing is taking place.

Unless otherwise specified, they apply to fencing with steel weapons. A separate section (1.8) refers to fencing with foam and plastic weapons.

**When sparring or competing** fencers must wear full protective clothing - i.e., mask, jacket, breeches/trousers, plastron and glove - in accordance with the clothing chart – Appendix 1 – as well as shoes, socks and, for women, protectors. For **lessons** see 4.3.

These standards and indeed all the Guidelines have been drawn up in cognisance of contemporary FIE Rules for Competitions. In the event of these Rules changing and laying down more rigorous safety requirements, BF will if appropriate update these Safety Guidelines, announcing the degree and timing of the application of the revised Rules in the UK.

In particular the FIE has laid down equipment standards which fencers must observe in order to compete in the Olympic Games, in World Championships and in all 'A' grade/ World Cup/Satellite and Zonal events<sup>1</sup>.

**Every fencer** is responsible for ensuring that their personal equipment is in a safe condition (cf. Rules for Competitions t.20.1).

Every fencer also has a duty of care to each of their opponents. For a safe, enjoyable sporting experience every fencer is expected to fence in a way that is safe and avoids hurtful, violent and dangerous actions (cf. also Rules for Competitions t.121.2) , taking action if they see any potentially dangerous situation.

Undue aggression or bad temper can cause harm and is not part of our fencing repertoire/culture. Coaches are expected to instil this duty in all their pupils and clubs should include this in their Codes of Conduct.

## 1.2 MASKS

Fencers must wear masks of appropriate size conforming at least to the minimum safety standard of CEN Level 1 and bearing the appropriate CEN safety mark (see chart - Appendix 1).

Masks must be checked for the following weaknesses and defects, if necessary, by a qualified armourer:

---

<sup>1</sup> Note that some competition organisers may demand standards that are more stringent than those laid down in this document

## BF SAFETY GUIDELINES

- i) Weaknesses in the steel mesh, softness, holes or excessive deformation of the hard shell from the original shape.
- ii) The bib not properly attached or revealing gaps between it and the mask or curling up.
- iii) Poor means of retention on the head, making the mask liable to come off. Fencers must wear a mask back-strap or some other approved method of mask retention<sup>2</sup> (see footnote)

Leon Paul <https://www.youtube.com/watch?v=wevdh2SU4Dw>

<https://www.youtube.com/watch?v=jbSn22CEfhk>

Allstar- <https://www.youtube.com/watch?v=f9-fMwKVXG8>

Generic <https://www.youtube.com/watch?v=lqKum5TsqAs>

Attempts must not be made to repair the steel mesh of a mask.

If the mask is weak or damaged, it must not be used.

### 1.3 JACKETS & BREECHES

- i) Fencers must wear jackets of appropriate size conforming at least to the minimum safety standard of CEN Level 1 and bearing the appropriate CEN safety mark. (see chart - Appendix 1).
- ii) Where breeches are required, fencers must wear breeches of appropriate size conforming at least to the minimum safety standard of CEN Level 1 and bearing the appropriate CEN safety mark (see chart - Appendix 1).
- iii) There should be a minimum of 10cms (4 inches) overlap between breeches and jacket when the fencer is on guard.
- iv) Jackets should fasten on the opposite side to the sword arm, or at the back.
- v) Breeches should reach and stay below the knee whilst fencing.
- vi) If both fencers are using non-electric foil blades or, at all three weapons size 0 blades, breeches may except in BF licenced competitions be replaced by full-length trousers or tracksuit trousers of sufficiently strong material, provided all openings/pockets are zipped/ sewn/taped closed – see chart.

Clothing must not be used which is damaged, shows visible tears or weakened by excessive use.

---

<sup>2</sup> A back-strap consists of elastic at least 35mm wide, secured to the mask side mesh at each end, passing UNDER any mask spring piece at the back, and tensioned to keep the mask firmly in place. It must stay fastened and tensioned during fencing.

For FIE events (ie, CEN level 2), masks with a fabric main retainer rather than a back spring piece are required to feature a separate back strap in addition.

### 1.4 PLASTRONS

Fencers must wear plastrons of appropriate size conforming at least to the minimum safety standard and bearing the appropriate CEN safety mark. For minimum safety standards for plastrons see chart, Appendix 1.

### 1.5 CHEST PROTECTORS

It is compulsory for anyone with female breasts to wear rigid chest protection. It is recommended that girls wear rigid chest protection (shaped or flat) from the age of ten or from the onset of puberty if earlier.

### 1.6 GLOVES

The gauntlet must be long enough to cover approximately half the forearm and remain over the sleeve of the jacket whilst fencing. Gloves must not have any opening or hole in the hand of the glove, even to allow the passage of the body wire; they should be inspected regularly for any holes and tears. Gloves must comply with the minimum standards set out in the chart (appendix 1)

The Rules do not prohibit the wearing of a glove on the unarmed hand.

### 1.7 SOCKS AND SHOES

Socks should always be covered by the bottom of the breeches, so that no bare skin is showing.

Suitable indoor trainer type shoes should be worn.

### 1.8 FENCING WITH FOAM OR PLASTIC WEAPONS, AND THE SABRELITE PROGRAMME.

- 1.8.1 For all fencing with foam or plastic weapons a plastic face-mask specifically designed for this purpose, or a regulation fencing mask should be worn.
- 1.8.2 For fencing with plastic weapons, a long-sleeved top should be worn, and the legs should be covered at least down to within 10cm above knee level.
- 1.8.3 For the SabreLite programme clothing rules see appendix 1

## 2. WEAPONS

### 2.1 WEAPONS - GENERAL

Note: The FIE and World Para Fencing (WPF) have laid down equipment standards that fencers must observe in order to compete in the Olympic Games, in the Paralympic Games, in World Championships and in all 'A' grade/ World Cup/Satellite and Zonal events. Other competition organisers may also demand these standards.

## BF SAFETY GUIDELINES

Weapons should be regularly inspected and checked to ensure they are in a safe, usable condition.

- i) Blades should be observed to ascertain if any portion displays obvious kinks or excessive plasticity that may lead to a break e.g., irregular or uneven curve or inability to correct such a bend by the usual straightening methods.
- ii) If blades develop sharp edges or splinters, these should be smoothed off with an emery cloth.
- iii) The end of the blade must be folded over onto itself or fashioned in one piece to form a button which, in the case of sabre blades, when viewed end on, must have a square or rectangular section of 4 mm. x 4 mm. minimum.

Almost all serious fencing injuries are caused by penetration by a broken blade, so please pay particular attention to the following section.

### 2.2 WEAPONS - BLADES

To reduce the risk of broken blades, never use a blade (or fence with someone who is using such a blade) if any portion displays obvious kinks or excessive plasticity that may lead to a break - e.g., irregular or uneven curve or inability to correct such a bend. Consider using a blade made out of a special steel, such as Maraging steel.

### 2.3 WEAPONS - BLADES FOR CHILDREN

Children under the age of ten should fence with weapon blades of size 0; children under the age of 14 should normally fence with weapon blades of size 3 (Foil) and 2 (épée and sabre) or less, as required in competitions for their age. This will enhance their safety, comfort, technique and enjoyment of our sport.

### 2.4 WEAPONS - TIPS & GUARDS

2.4.1 **Weapon tips** should conform to the FIE requirements. Sabre blades should be checked regularly as wear and tear risks reducing the tip size, making the penetration risk higher (see footnote <sup>3</sup>, *dimensions of sabre blade tips*).

The point of a non-electric foil or épée (including a dummy electric foil blade) must be

#### <sup>3</sup> Dimensions of a Sabre Blade Tip

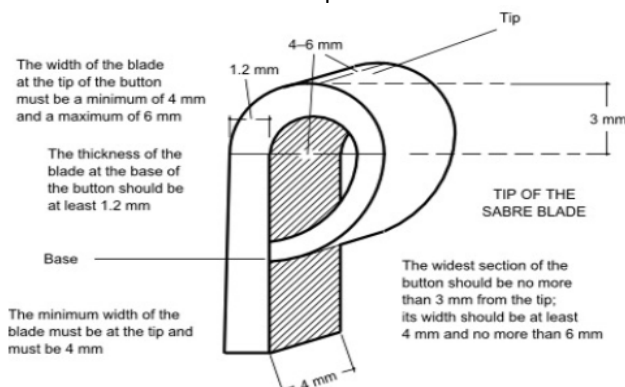

## BF SAFETY GUIDELINES

covered with a commercially produced plastic button in good condition or an integrated button.

- 2.4.2 **Weapon Guards** - Continuous use of a weapon can leave sharp edges round the guard circumference, which are a potential hazard. Such guards must not be used. Guards which are dented enough to risk trapping a point must not be used.

### 3. SPECIAL GUIDELINES FOR CHILDREN

#### 3.1 CHILD PROTECTION/WELFARE:

See the BF child protection/welfare policies <[BF child protection/welfare policies \(https://www.britishfencing.com/policy-zone/welfare-policies-guidelines/\)](https://www.britishfencing.com/policy-zone/welfare-policies-guidelines/)>

#### 3.2 BLADE SIZES

See 2.3.

#### 3.3 CLOTHING

Fencing with steel weapons – see appendix 1

Fencing with foam/plastic weapons – see 1.8

#### 3.4 LESSONS/CLASSES

See 4.3 and appendix 3.

### 4. FENCING ACTIVITIES

Club officers, coaches/instructors and competition organisers are under an obligation to conduct risk assessments for all fencing activities in which they are involved and to act in accordance with their conclusions;

Risk assessment templates for running competitions and club activities can be found here:

<https://www.britishfencing.com/running-a-fencing-event/>

<https://www.britishfencing.com/club-resources/>

Club officers, coaches/instructors and competition organisers all have responsibility for ensuring that the accident prevention precautions in respect of premises are observed.

They should all ensure that at all times the rules to prevent accidents are obeyed including during lessons and, as far as practicable, that individual fencers are taught to and indeed do observe their own accident prevention responsibilities.

Importantly, they should also remember that failure to observe the risk assessment in some circumstances could risk invalidating the insurance cover.

### 4.1 VENUES

- 4.1.1 The venue must be adequate for the activity.
- 4.1.2 The venue must have an adequate first aid kit (see also section 6). It is highly desirable that there should be a rapidly accessible defibrillator available. This is essential for veteran competitions.
- 4.1.3 All fencers must be made aware of emergency evacuation procedures.
- 4.1.4 The fencing area should be such that fencers performing all normal fencing movements, however fast, are not in danger of slipping.
- 4.1.5 Cables on the ground should be arranged so that they present a low risk of tripping to fencers and/or spectators.
- 4.1.6 Spectators should not be allowed so near the sides of the piste that there is a risk of collision with a fencer who fleches off the piste nor any risk that they may be hit by a weapon, Furthermore, spectators must never interfere with the safe positioning of the fight officials.
- 4.1.7 Non-competing children, whether accompanied/carried or not, must not be allowed inside the field of play.
- 4.1.8 Particular care should be taken if it is necessary to cross an area on which fencing is taking place.
- 4.1.9 In the cases of lessons and classes the coach/instructor has particular responsibility to ensure the above points are covered.
- 4.1.10 **Mains operated equipment**
  - 4.1.10.1 Mains operated equipment that requires an earth should not be used unless it is correctly earthed using a plug with an earth pin and connected to mains supply via a Residual Current Device (R.C.D.).
  - 4.1.10.2 Mains cables must not be placed on top of or under the conductive pistes, or in any other situation where they could be subject to rubbing or pressure.
  - 4.1.10.3 Cases of apparatus should only be opened when disconnected from the supply.
  - 4.1.10.4 A fuse should not be replaced before a qualified electrician or other competent person has found and rectified the fault that caused the fuse to blow.
  - 4.1.10.5 Electrical equipment should be used only if it is made by a reputable manufacturer, and it should not be modified except by the manufacturer or with their permission.
  - 4.1.10.6 All mains equipment, including mains leads, should be subject to a visual inspection by a qualified electrician or other person qualified at least yearly and to a Pat test every 3 years.

## BF SAFETY GUIDELINES

- 4.1.10.7 All current regulations regarding the use of mains powered equipment, where it is accessible to the public, must be observed.

### 4.2 CLUBS, LESSONS, CLASSES

- 4.2.1 Every club is required to have an incident reporting mechanism by means of an incident book or other facility whereby accidents, injuries and near misses are recorded – see also 4.6.
- 4.2.2 Fencers in a club or class who have ongoing health problems (e.g asthma, diabetes) which may cause difficulties during training, should declare this on registration. Any concerns should be discussed with the fencer or their responsible adult and medical opinion obtained if necessary.
- 4.2.3 A class coach/instructor must ensure that:
- 4.2.3.1 The class does not exceed the appropriate numbers for the available space and the available number of instructors (see appendix 3).
  - 4.2.3.2 All fencers have been given a thorough briefing on good safety practices in fencing and been made aware of these BF Safety Guidelines.
  - 4.2.3.3 All fencers have been advised of the correct use of the equipment and the potential dangers of mishandling it.
  - 4.2.3.4 The class is not left unattended.

For further details see Appendix 3.

### 4.3 LESSONS/CLASSES - PROTECTIVE CLOTHING

During lessons, both individual and class:

- 4.3.1 For plastic weapons only, when giving individual lessons the coach/instructor should wear a mask.
- 4.3.2 When steel weapons are being used:

#### The coach/instructor

- should normally wear the appropriate full protective clothing; and
- must always wear the following protective items: mask; fencing jacket and plastron or a teaching jacket and plastron combined, glove (*but see footnote <sup>4</sup>*).

#### The pupil

---

<sup>4</sup> Protective clothing is not required if the coach is simply supervising a class which at no time involves face to face teaching or demonstrating whilst either pupil or coach is holding a weapon

## BF SAFETY GUIDELINES

- should normally at a minimum wear the appropriate full protective clothing required for those fencing non-electric foil -see chart - Appendix 1.

NB If the coach/instructor, having done a risk assessment considers that particular circumstances justify less than this level of full protective clothing being worn, they should draw the attention of the pupil or parent/guardian to the increased notional risk of accident or injury that could result because full protective clothing is not worn).

- must always wear, mask and glove, t-shirt and shorts reaching to within 10cm above the knee.

In Epee class lessons when pupils are practicing movements in pairs the legs must not be included in the target unless the pupils are wearing at least 350N breeches and long socks.

For more detailed advice on the running of classes see Appendix 3

### 4.4 SPARRING IN BEGINNER/TASTER CLASSES - PROTECTIVE CLOTHING

Exceptions to the requirements set out in Appendix 1 are as follows:

- 4.4.1 When sparring is supervised by a coach and a risk assessment has been done, fencers can wear tracksuit trousers rather than breeches at the discretion of the coach or club manager even when size 4/5 electric blades are being used.
- 4.4.2 Epee fights must not include the legs as target unless the pupil is wearing at least 350N breeches and long socks, irrespective of blade size or ages of fencers.

### 4.5 COMPETITIONS

- 4.5.1 Piste-laying: A risk assessment should take place, taking into account all relevant factors including: the age group; the weapon; the standard of fencing; and a safe position for the referee and for spectators.

Subject to this specific competition risk assessment the following distances are recommended:

- 4.5.1.1 between the edges of adjacent pistes on the side where score boxes are placed: not less than 1 metre.
- 4.5.1.2 between the edges of adjacent pistes on the side used for refereeing: 2.5 metres. If the distance is less, the referee should wear some form of protection, such as a mask or goggles.
- 4.5.1.3 between any person (e.g., scorers, box operators, spectators) and the edge of the piste: 1.25 metres.

## BF SAFETY GUIDELINES

- 4.5.1.4 total distance between the rear line of two pistes placed end-on: not less than 2 metres.
- 4.5.1.5 there should be an unobstructed run back beyond each rear line of as near 1.5 metres as possible, which should be unobstructed by chairs, cables, fencing equipment, or by anything else which might trip up or obstruct a fencer.
- 4.5.2 Referees should use their best endeavours to ensure that these Guidelines are observed, in particular checking on those concerning competitors' personal equipment, especially blades and masks and ensuring that proper plastrons are worn.
- 4.5.3 Referees should ensure that spectators do not encroach on the field of play.

### 4.6 ACCIDENT AND INJURY REPORTING

Clubs and competition organisers are required to have an incident reporting mechanism and are expected to report significant incidents. Thus in the case of any accident, injury or serious medical incident they and/or anyone else concerned should ensure a [BF Accident and Injury Report \(https://app.smartsheet.com/b/form/58ff7faa98ed427fa6f9049f8ea99762\)](https://app.smartsheet.com/b/form/58ff7faa98ed427fa6f9049f8ea99762) is submitted. See also introduction and 4.2.1. This helps to keep our sport of fencing safe.

Near miss incidents which did not cause harm but could have, including a mask falling off, should also be reported.

## 5. FIRST AID

### 5.1 FACILITIES/PERSONNEL

**Clubs:** Premises should have at least a basic first aid box available and a named person responsible for making sure it is accessible and re-stocked as necessary. It is recommended that all clubs keep a basic first aid manual with the box and have a method of recording incidents.

**Events:** Organisers using sports centres must be aware of the first aid facilities available and make sure that they are accessible.

Although significant injuries are unusual, it is necessary at large competitions to ensure appropriate medical cover and first aid supplies. For veteran events an accessible defibrillator must be available and it is desirable that all clubs and events should have access to a defibrillator, on site or nearby.

Risk Assessments should be carried out to determine the appropriate level of medical care and facilities and personnel required. This is not intended to be a legal requirement or substitute good judgement or practice but as a framework to guide event organisers to provide appropriate cover. The event organiser should always check qualifications and liability insurance cover.

### 5.2 INTERVENTION

- 5.2.1 The official responsible for any fencing activity should ensure that immediate use of a telephone is available in the event of a significant injury. 111 is the number for medical problems but 999 can also be used in urgent situations.
- 5.2.2 A doctor has an ethical duty to intervene and do their best. If more than one doctor or paramedic is present, the most appropriately qualified person should take charge.
- 5.2.3 A first-aider appointed for this purpose also has a duty to assist.
- 5.2.4 In the UK members of the public are not under a legal duty to intervene in an emergency but if they do their best, they are unlikely to be criticised. Therefore, the average club member should step in and help another fencer if they are injured, in the absence of anyone medically qualified.
- 5.2.5 Coaches/instructors as sporting activity professionals, (in the absence of anyone more qualified) are likely to owe a duty of care to intervene. They would be judged by the action of a reasonable coach/instructor with their skill set. They may be liable if they act recklessly or negligently but not otherwise.

## 6. APPENDIX 1: MANDATORY MINIMUM STANDARDS - CHART OF BF CLOTHING & WEAPON RULES IN CLUBS AND AT COMPETITIONS

Socks should be worn with breeches in accordance with 1.7

Chest protectors should be used in accordance with 1.5

### 6.1 ALL PLASTIC/FOAM FENCING

Notes	Blades	Jackets	Plastron	Trousers/ breeches	Masks	Gloves
Coaches giving lessons must wear masks	Plastic/ Foam	A long-sleeved top	Not required	Legs covered at least down to within 10cm of knee level.	Plastic face-mask specifically designed for this purpose or regulation fencing mask	Not Required

### 6.2 STEEL BLADES - CLUB BEGINNER COURSE (INC SUPERVISED SPARRING)/PUBLIC COME AND TRY

Notes	Blades	Jackets	Plastron	Trousers/ breeches	Masks	Gloves
Participants must be beginners and all sessions are under active coach supervision	All lengths	CEN 1 350 Newtons	CEN 1 350 Newtons or integrated 350 Newtons plastron	<u>At foil &amp; sabre/ épée if target excludes legs</u> Full length Trousers with openings/pockets, zipped/sewn/taped closed <b>or</b> Seated Fencing – 350N apron <u>Epée if target includes legs</u> CEN 1, 350 Newtons breeches & full – length socks	CEN 1 (350N. bib) including one back safety strap	Any fencing glove

## BF SAFETY GUIDELINES

### 6.3 STEEL BLADES - FENCER TAKING LESSON

<b>Notes</b>	<b>Blades</b>	<b>Jackets</b>	<b>Plastron</b>	<b>Trousers/breeches</b>	<b>Masks</b>	<b>Gloves</b>
A Normally	Any	CEN 1 350 Newtons	CEN 1 350 Newtons	Full length Trousers with openings/pockets zipped/sewn/taped closed or fencing breeches	CEN 1 (350N. bib) including back safety strap	Any fencing glove
But B: If coach/ instructor's risk assessment considers particular circumstances justify lesser level and warned of increased notional risk	As above	T-shirt	Not required	Shorts reaching to within 10cm above the knee	As above	As above

### 6.4 TRADITIONAL NON-ELECTRIC FOIL BLADE ACTIVITIES

Fencing with the traditional non-electric foil blade as used before the invention of electric foil (both fencers)

<b>Note</b>	<b>Blades</b>	<b>Jackets</b>	<b>Plastron</b>	<b>Breeches</b>	<b>Mask</b>	<b>Gloves</b>
Foil	Non-electric foil blades, tips must be covered by rubber buttons	CEN 1 350 Newtons	CEN 1 350 Newtons or integrated 350 Newtons plastron	Full length Trousers with openings/ pockets, zipped/sewn/taped closed or fencing breeches	CEN 1 (350N. bib) including back safety strap	Any fencing glove

## BF SAFETY GUIDELINES

### 6.5 SABRELITE

Note	Blades	Jackets	Plastron	Trousers/breeches	Masks	Gloves
Courses with trained coach. Equipment package from Leon Paul Equipment supplied by BF.	Sabre size 3, rubber tips	CEN 1  350 Newtons	350 Newtons plastron integrated with jacket	Full length Trousers with openings/ pockets, zipped/sewn/taped closed or fencing breeches	CEN 1 (350N. bib) including back safety strap	Any fencing glove

### 6.6 UNDER 10/SIZE 0 BLADES (BOTH FENCERS)

Where both fencers are aged under 10 and fencing with size 0 blades.

Note	Blades	Jackets	Plastron	Trousers/ breeches	Masks	Gloves
Both fencers using size 0 blades	Size 0	CEN 1  350 Newtons	CEN 1  350 Newtons	Full length Trousers with openings/pockets zipped/sewn/taped closed or fencing breeches  <b>BUT IN BF LICENSED COMPETITIONS OR ANY ACTIVITY WHERE LEG IS A VALID TARGET</b>  CEN 1 (350 Newtons) breeches	CEN 1 (350N. bib) including back safety strap	Any fencing glove

## BF SAFETY GUIDELINES

### 6.7 UNDER 14 FENCING WITH SIZE 2/3 BLADES

Where both fencers are aged under 14 and fencing with size 3 blades (foil) or size 2 blades (epee and sabre).

Note	Blades	Jackets	Plastron	Trousers/breeches	Masks	Gloves
	Size 3 (foil) and 2 (épée and sabre)	CEN 1 350 Newtons	CEN 1 350 Newtons	CEN 1 350 Newtons	CEN 1 (350N. bib) including back safety strap	Any fencing glove

### 6.8 BRITISH YOUTH CHAMPIONSHIPS

Refer to BF website: <https://www.britishfencing.com/byc-kit-requirements/>

### 6.9 OTHER SPARRING IN CLUBS

Notes	Blades	Jackets	Plastron	Trousers/breeches	Masks	Gloves
	All remaining sizes	CEN 1 350 Newtons	CEN 2 800 Newtons	CEN 1 350 Newtons	CEN 1 (350N.bib) including back safety strap	<b>Sabre:</b> Sabre glove bearing the FIE 800N label <b>Foil/Epée:</b> Any fencing glove

## BF SAFETY GUIDELINES

### 6.10 BRITISH NATIONAL CHAMPIONSHIPS (CADET, JUNIOR, U23 & SENIOR)

Note	Blades	Jackets	Plastron	Trousers/ breeches	Masks	Gloves
	All	CEN 1 350 Newtons	CEN 2 800 Newtons	CEN 1 350 Newtons (1)	CEN 2 (1600N. bib, FIE mark) with two rear safety systems (securing devices), so fitted that they comply with Rule m.25.7.f.	<b>Sabre:</b> Sabre glove bearing the FIE 800N label <b>Foil/Epée:</b> Any fencing glove

### 6.11 OTHER UK COMPETITIONS

Note	Blades	Jackets	Plastron	Trousers/ breeches	Masks	Gloves
Organisers of non-ranking competitions may decide on higher levels but see 6.6 and 6.7	All	CEN 1 350 Newtons	CEN 2 800 Newtons	CEN 1 350 Newtons (1)	CEN 1 350N.bib including back safety strap	<b>Sabre:</b> Sabre glove bearing the FIE 800N label <b>Foil/Epée:</b> Any fencing glove

### 6.12 ALL FIE & U17/U23 EFC COMPETITIONS

Includes World Cups, Grand Prix's, Satellites, Zonal and World Championships, all age groups. EFC U17 (cadet) and U23 circuit Events.

Note	Blades	Jackets	Plastron	Trousers/ breeches	(1) Masks	Gloves
	Maraging	CEN 2 800 Newtons FIE mark	CEN 2 800 Newtons, FIE mark	CEN 2 800 Newtons, FIE mark	CEN 2 (1600N. bib, FIE mark) with two rear safety systems (securing devices), so fitted that they comply with Rule m.25.7.f.	<b>Sabre:</b> Sabre glove bearing the FIE 800N label <b>Foil/Epée:</b> Any fencing glove

## BF SAFETY GUIDELINES

- (1) Note The wearing of tracksuit trousers over 350/800N breeches is currently allowed (competition and training), on condition that the trousers are tapered/straight cut (i.e. not baggy), with all openings and pockets zipped or sewn or taped closed. Implementation of this addition to the Safety Guidelines will be monitored by the Safety Committee and subject to regular review. See <<https://www.britishfencing.com/policy-zone/safety-policies-guidelines/>>

## 7. APPENDIX 2: LEGAL RESPONSIBILITY

- a) A fencer is generally deemed at Law to accept the ordinary risks involved in fencing.
- b) Examples of ordinary risks that a fencer is deemed to accept are accidents arising from breakage of blades, or from normal bodily contact with an opponent, arising in the normal course of a bout. However, a fencer may possibly be legally liable if he injures an opponent by an action that is illegal under the Rules of fencing or is recklessly violent.
- c) All fencers are strongly recommended to obtain the insurance cover provided by joining British Fencing. This cover is provided automatically among the benefits of membership.
- d) Fencers can limit the risk of legal liability by fencing within the Rules and ensuring that their equipment is safe.
- e) The Rules for Competitions make it clear that each fencer is responsible for the safety of their own equipment and that the organisers and referees are not responsible. Organisers of competitions will normally wish to include a clause on entry forms, - and brochures advertising competitions seeking to exclude liability. A suggested form of words is as follows:
- f) "Each fencer is personally responsible for making sure that their clothing and equipment conform to BF rules and are in good condition.
- g) Neither BF nor the organisers of the competition, nor any official or referee involved in the competition is responsible for these matters, or for any accident, loss or damage to persons or property however caused".
- h) The degree of liability that may fall on organisers and referees is unclear and depends on the particular circumstances. In any event, they should take care to ensure so far as is reasonably possible that the Rules governing safety of equipment and conduct are properly enforced.
- i) When fencers under the age of 18 are entering a competition, they must have the consent of a parent or other person in 'loco parentis' to take part and the entry process must make provision for this. (For all FIE competitions also see Rules for Competitions Article o.29.5).
- j) BF has an indemnity policy against legal liability. The insurers have agreed that all BF registered competitions fall within this policy.

## 8. APPENDIX 3: ADVICE ON RUNNING CLASSES

In addition to section 4 of the Safety Guidelines:

1. Never allow fencers to begin or continue fencing if their clothing or weapon is inappropriate, or unsafe (see these Safety Guidelines). Remember, it is the coach/instructor's responsibility that fencers are always safely attired and equipped.
2. All fencers must, when they are not fencing or practising, carry their weapons either by the pommel with the points towards the floor or by gripping the point, with the weapon hanging down vertically.
3. All fencers must be taught not to put on their masks using both hands while holding a weapon – but to put the mask on first.
4. NEVER give the instruction to begin fencing without checking that all fencers are wearing their masks correctly.
5. All fencers must be told to stop fencing immediately if a mask falls off, a blade breaks or a point or button falls off.
6. The instructor must identify unsafe practices, even if those involved are not under their control. The law recognises that all instructors have a duty of care to ensure that all those who take part in fencing do so without endangering themselves or others.

### **ADDITIONALLY, THE FOLLOWING APPLY SPECIFICALLY FOR CHILDREN'S CLASSES**

7. Generally, no more than twelve children per coach/instructor should fence at any one time (a larger number may be appropriate depending on the age, experience etcetera of the pupils). If the ratio in the group is higher than this, the group should be split into relays for fencing activity (larger numbers can take part together in footwork and games without weapons). In the case of groups of young children fewer than twelve may be an appropriate maximum.
8. Never allow fencers to act irresponsibly with equipment.
9. Always make your fencers aware of the potential hazards of mishandling their weapon.
10. Ensure all masks are fitted correctly before allowing fencers to start fencing, and make sure that they do not remove them before being instructed to do so (reminder: For all sparring with plastic weapons a plastic facemask specifically designed for this purpose or regulation fencing mask should always be worn).
11. With children aged under 8 ensure that any regulations applicable to this age group are complied with.
12. BF maintains a central register of qualified coaches. Depending on their role they may require additional Safeguarding training and criminal record checks – details to be found at [www.britishfencing.com](http://www.britishfencing.com).

13. It is strongly recommended that any organisation engaging a fencing coach check that they are on the BF register. **Affiliated clubs are required to use BF registered coaches.**

## 9. APPENDIX 4 - CE, CEN AND FIE MARKINGS

**Information on the markings on protective fencing equipment when buying in the UK and Europe from reputable manufactures.**

If you are purchasing protective equipment (other than FIE labelled equipment) outside of Europe you are responsible for checking that the standard is equivalent. BF is not responsible for equipment testing or providing quality assurance. Any concerns about counterfeit equipment should be reported to BF and raised with trading standards. *Please note if there is an accident involving equipment that does not have the correct quality marks insurance cover may be affected.*

### Summary Guidelines

1. Buy from a reputable supplier
2. Check for a CE mark plus name of the manufacturer or importer of record - required on all protective equipment (for legal sale in UK and mainland Europe)
3. Review the BF Clothing and Weapon Rules (appendix 1) to work out what is the right level of protective equipment (350/800/1600 FIE) you need for the fencing activity you are undertaking - there are different standards for different activities from sparring in clubs to competing at international events.
4. Check there is a CEN mark - a minimum of CEN Level 1 is required for entry level protective equipment (recreational club use) – see appendix 1.
5. Check the 350/800/1600 N markings
6. If you are competing internationally your kit will need an FIE marking.

### Protective Equipment

- Fencing Jackets
- Breeches / Trousers (protect hips/thighs)
- Plastrons (Underarm protectors)
- Fencing Masks with CEN Level 1 certification
- Gloves

### More Information

CE Marking

## BF SAFETY GUIDELINES

A CE logo is the manufacturer declaring that the product complies with relevant UK/EU safety, health, and environmental laws. Without a CE mark, equipment is not legal for sale in the UK or mainland Europe. Therefore anyone in Britain or Europe selling you equipment that they have bought from outside Britain or mainland Europe should have a CE certificate of Conformity plus the separate Technical file for it - they fall into the legal category of "Importer of Record", taking legal responsibility for the product's safety and compliance and if there's an accident they need to show that they followed the CE regulations.

If therefore you have imported equipment and are selling it on in this country you are by definition responsible for CE certification; you must have proof that you have seen the CE certificate of conformity and the technical file. Just stating that an item has passed CE level 1 or CEN level 2 standards doesn't cover you and you are liable - and this can come with big fines or in extreme cases prison.

### CEN Markings

CEN is a European safety standardisation that defines minimum safety performance for protective equipment in fencing.

Level 1 (approx. 350 N) signifies the item provides a minimum penetration resistance suitable for some fencing environments (see the Safety Guidelines)

For certain national competitions and EFC/FIE competitions, higher CEN levels (e.g., Level 2 / FIE-grade) with greater protective thresholds are required. CEN Level 2 standards can overlap with FIE clothing standards, but just because an item meets this it is NOT automatically FIE-approved for use.

### FIE Marking

An FIE marking means a piece of fencing equipment is approved by the sport's world governing body, the Fédération Internationale d'Escrime, and meets their highest safety requirements. FIE equipment is required for FIE level international competition and some EFC level competition (more info on EFC website)

FIE marking requires:

- Approved materials
- Approved construction
- Factory audits
- Batch testing
- Ongoing compliance

So a jacket can be 800 N but not FIE-legal.

## BF SAFETY GUIDELINES

*British Fencing, 1 Baron's Gate, 33 Rothschild Road, London W4 5HT  
A company limited by guarantee no 1917099.  
Registered in England & Wales. VAT registration 226658348*